

Physics Exploration Homework Supplement

Go to the Physics Exploration Center. Enter through the resource room 311/312 Thaw Hall.

(a) Before starting the exploration, predict whether a ball dropped from your hands while you are standing on the moving walkway at the airport will fall behind you, in front of you, or next to you (ignore air resistance). Justify your answer.

Draw the shape of the trajectory of the ball as perceived by (i) you, (ii) the person who is standing next to the walkway (but is not on it). Justify the drawings.

Now go to the set up with a ballistic cart on a near frictionless track. You can turn on the power switch on the cart and push the ball inside the muzzle of the ball holder. There will be a popping sound when the ball attaches to the holder properly.

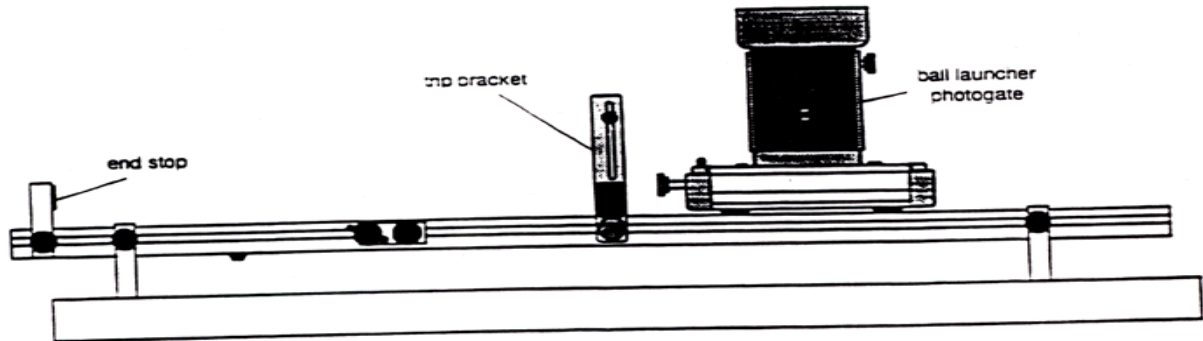

(b) Before starting the exploration, predict whether a ball shot up from the cart moving on the horizontal frictionless track will land in the holder if it is shot up from the cart. Explain your reasoning.

(c) Push the cart with various initial velocities (and then let go). When the cart goes past the trip bracket (shown in the figure) it launches the ball perpendicular to the track. Now push the cart GENTLY at various initial velocities and note whether the ball lands in the holder or not at a later time.

(d) Does it matter how fast you push the ball, whether the ball lands in the holder?

(e) Ignore friction and assume that the horizontal velocity remains constant throughout the motion. A photogate is provided which can be used to measure the horizontal velocity of the cart. Using the photogate you can find the time taken by the cart to cover 4 cm distance on the track (shown on the computer). Find the constant horizontal velocity of the cart.

(f) For at least one case, measure the distance traveled by the cart between launching and landing of the ball. Use a meterstick to find the maximum height that the ball achieves between launch and landing (assuming that its initial height in the holder is zero). Also, find the maximum height and the initial velocity of the ball perpendicular to the track during launching using the equations of kinematics. Does the result for maximum height match what you measure using the meter stick.

(g) Sketch roughly the shape of the trajectory of the ball? Do you know what this shape is called?

(h) What did you think was the most interesting feature of this experiment (there is no fixed answer for this question)?