

## Contents

|   |  |   |
|---|--|---|
| 1 | What are voltage, current, and resistance? | 1 |
| 2 | Circuits                                   | 2 |
| 3 | What will we actually do?                  | 4 |

## 1 What are voltage, current, and resistance?

First, we need to define, briefly, some basic ideas.

1. **Voltage.** Macroscopic matter is made up of atoms and molecules which are bound together by electrical forces. The atoms are made up of electrically neutral neutrons, and positively charged protons. In batteries, or other sources of electrical power, positive and negative charges are separated. Since unlike charges attract each other, work must be done to separate them. You have already studied conservation of (mechanical) work and energy. Electrical energy is just another form of energy, and what we have found is that all kinds of energy can change form, from one kind to another, but the total energy is conserved. Under the right conditions, we can get back the work we put into separating the charges. A source of electricity is rated by the "voltage", or work per unit charge which could be recovered if a unit positive charge moved from the "positive" side of the battery or electricity source to the "negative" side. (or, which is what usually happens, a unit negative charge moved from the "negative" side of the battery to its "positive" side.
2. **Current.** The amount of charge which passes an observer's station per unit time is called the electrical current. Since Voltage is work/unit charge and current is charge/unit time, we see that Voltage \* Current is Work/time, which is power, or the rate at which work is done. The utility company charges by the total work (or power \* time), but you

need to know how much power an electrical device can use, and how much power your electrical power source provides, before connecting your device to your electrical power source.

3. **Resistance.** When charges have been separated onto positive and negative "terminals", and suddenly the two terminals are touched together, the charges will move very quickly to equalize the charge... and there will be a large spark, which corresponds to a huge instantaneous current (transfer of charge over a very short time). On the other hand if the terminals are in a vacuum, no current will flow between them. Any intermediate situation will give some intermediate current. The "resistance" of a given piece of material placed between two terminals with difference in voltage  $V$  is defined as:  $V = i * R$ , where  $i$  is the current which flows between the two terminals when the resistance  $R$  is connected.  $R$  can always be defined in this way. For some materials,  $R$  depends on the voltage across the two ends of the material, or it may depend on the temperature of the material. For other materials,  $R$  is nearly independent of temperature, the voltage across it, and the current through it. Materials with variable resistance are fascinating both for their function and their construction. If you go on to design electrical circuits you will work with such variable resistor components as diodes and transistors, or you might worry about the breakdown voltages of gases at which current starts to flow. But in our lab today, we will start at the beginning with materials called "resistors", for which the "resistance"  $R$  is independent of current and voltage. That is, a graph of voltage vs current would be a straight line, with slope  $R$ .

## 2 Circuits

There are two kinds of circuits:

### Series Circuits

First, **series**, in which the electrical current flows through the components one after the other "in series". In a series circuit, the current is the same in each element.

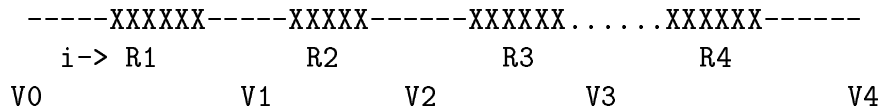

Figure 1

Figure 1 shows a series circuit. If  $V_0 = 0$ , then the work done in moving a charge from the left hand side of  $R_1$  to the right hand side of  $R_4$  will be:

$$V_4 = V_1 + (V_2 - V_1) + (V_3 - V_2) + (V_4 - V_3)$$

(since the work done to move a charge through all the resistors is just the sum of the work to move the charge through each of the individual resistors in turn.

Therefore:

$$V_4 = i * R_1 + i * R_2 + i * R_3 + i * R_4$$

or:

$$V_4 = i * (R_1 + R_2 + R_3 + R_4)$$

and we see that

$$R_{eff,series} = R_1 + R_2 + R_3 + R_4.$$

### Parallell Circuits

Next, parallel, in which there are different "parallel" paths which current can take, shown in Figure 2.

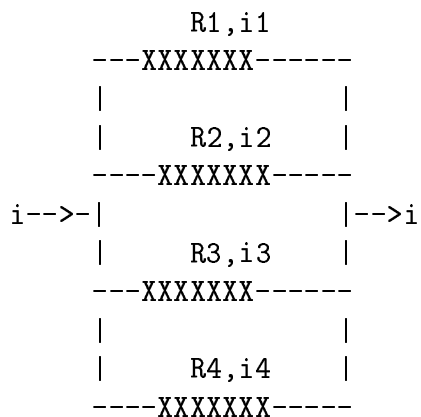

Figure 2

For parallel circuits, since all the resistors are connected at the beginning and the end of the current paths it takes the same work for a charge to travel through any resistor. Since charge must be conserved, the total current must split, giving:

$$i = i1 + i2 + i3 + i4$$

But for each resistor,  $V=iR$ , so,

$$i = V/R1 + V/R2 + V/R3 + V/R4$$

, which gives:

$$1/Ref f, parallel = 1/R1 + 1/R2 + 1/R3 + 1/R4$$

You can show that there is a simple form for two resistors:

$$Ref f, parallel = R1 * R2/(R1 + R2).$$

Note above that the series effective resistance is always larger than the resistance of any one resistor, and the  $R_{\text{eff, parallel}}$  is always less than the resistance of any one resistor.

### 3 What will we actually do?

Your equipment will be a battery, an electrical meter which can measure voltage and current, a clipboard for electrical connections, and some (nearly) identical resistors.

First, connect your resistors in series, and in series with the battery. By connecting the meter connections to opposite ends of each resistor, one at a time, measure the voltages across each resistor, and check that the total voltage is the sum of the individual voltages. Check the current at different points in the circuit by connecting your meter (set on the current scale) between two resistors (in series with the rest of the circuit). Try the experiment for different numbers of resistors. Think of a way to display your results in a graph, to demonstrate Ohm's law ( $V=iR$ ) for a series circuit.

Next, connect your resistors in parallel, and in parallel with the battery. Check that the voltage across each resistor is the same. Check the currents flowing through each resistor (by putting one end of the meter connections to the common voltage point, and the other to the tip of the resistor.. that is, the meter will be in series with the resistor whose current you are measuring, and the meter and the resistor being measured will be in parallel with the rest of the resistors. Again, try your experiment for different resistors, and think of a way to display your results in a graph, to demonstrate Ohm's law for a parallel circuit.